

Panasonic

Operating Instructions

Digital Cordless Phone

Model No. **KX-TG7200TW**

KX-TG7202TW

KX-TG7209TW

Digital Cordless Answering System

Model No. **KX-TG7220TW**



KX-TG7200
KX-TG7209

This unit is Caller ID compatible. Please be sure that if both of you and the calling party's lines support Caller ID function without any problem at the same time or not.

Charge the batteries for about 7 hours before initial use.

Please read these operating instructions before using the unit and save them for future reference.

Table of Contents

Preparation	
Introduction	3
Accessory information	4
Important information	5
Controls	7
Displays	8
Connections	8
Battery installation and replacement	9
Battery charge	10
Turning the power on/off	11
Setting up the unit before use	11
Making/Answering Calls	
Making calls	13
Answering calls	13
Useful features during a call	14
Phonebook	
Handset phonebook	15
Handset Settings	
Handset settings	17
Special instructions for time settings	18
Base Unit Settings	
Base unit settings	19
Caller ID Service	
Using Caller ID service	21
Caller list	21
Voice mail service	22
Answering System Features	
Answering system	23
Turning the answering system on/off	23
Greeting message	23
Listening to messages	24
Direct command operation using the handset	25
Remote operation	25
Answering system settings	27
Multi-unit Operation	
Operating additional units	29
Registering a handset to the base unit	29
Intercom between handsets	30
Transferring calls between handsets	30
Conference calls	30
Copying phonebook entries	31
Useful Information	
Character entry	33
Error messages	35
Troubleshooting	35
Specifications	40
Index	
Index	41

Preparation

Introduction

Thank you for purchasing a new Panasonic digital cordless phone.

For your future reference

Attach or keep original receipt to assist with any repair under warranty.

Serial No. (found on the bottom of the base unit)
Date of purchase
Name and address of dealer

Note:

- In the event of problems, you should contact your equipment supplier in the first instance.
- PSST has rights to make alteration in this manual, and will not notify for the modification separately.
- All contents of this manual should take the reality product as the criterion.

Your phone

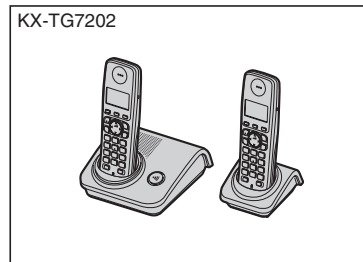
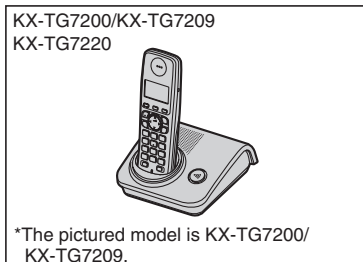

Preparation

Accessory information

Supplied accessories

No.	Accessory items	Quantity	
		KX-TG7200 KX-TG7209 KX-TG7220	KX-TG7202
①	AC adaptor for base unit (Part No. PQLV207TW)	1	1
②	Telephone line cord	1	1
③	Rechargeable batteries AAA (R03) size	2	4
④	Handset cover*1	1	2
⑤	Charger (Part No. PQLV30055Z)	—	1
⑥	AC adaptor for charger (Part No. PQLV209TW)	—	1

*1 The handset cover comes attached to the handset.

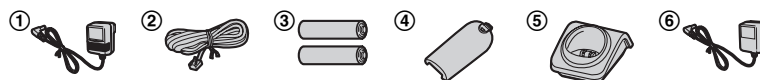

Additional/replacement accessories

Please contact your nearest Panasonic dealer for sales information.

No.	Model No.	Description
①	KX-TGA721TW	Additional Digital Cordless Handset
②	KX-TCA727EX	Wall-Mounting Adaptor
③	KX-TCA718EX	Belt Clip



Note:

- When replacing the batteries, use only 2 rechargeable AAA (R03) size nickel metal hydride (Ni-MH) batteries. We recommend using Panasonic rechargeable batteries.
- Replacement batteries may have a different capacity from that of the supplied batteries.

Preparation**Important information****General**

- Use only the AC adaptor supplied with this product, noted on page 4.
- Do not connect the AC adaptor to any AC outlet other than a standard 110 V AC outlet.
- This product is unable to make calls when:
 - the portable handset battery(ies) need recharging or have failed.
 - there is a power failure.
 - the key lock feature is turned on.
- Do not open the base unit, charger, or handset other than to replace the battery(ies).
- This product should not be used near emergency/intensive care medical equipment and should not be used by people with pacemakers.
- Care should be taken that objects do not fall onto, and liquids are not spilled into, the product. Do not subject this product to excessive smoke, dust, mechanical vibration or shock.

Environment

- Do not use this product near water.
- This product should be kept away from heat sources such as radiators, cookers, etc. It should also not be placed in rooms where the temperature is less than 5 °C or greater than 40 °C.
- The AC adaptor is used as the main disconnect device. Ensure that the AC outlet is installed near the product and is easily accessible.

Warning:

- To prevent the risk of electrical shock, do not expose this product to rain or any other type of moisture.

- Unplug this product from power outlets if it emits smoke, an abnormal smell, or makes unusual noise. These conditions can cause fire or electric shock. Confirm that smoke has stopped emitting and contact an authorised service centre.
- Do not spill liquids (detergents, cleansers, etc.) onto the telephone line cord plug, or allow it to become wet at all. This may cause a fire. If the telephone line cord plug becomes wet, immediately pull it from the telephone wall jack, and do not use.
- Do not place or use this product near automatically controlled devices such as automatic doors and fire alarms. Radio waves emitted from this product may cause such devices to malfunction resulting in an accident.
- Regularly remove any dust, etc. from the AC adaptor/power plug by pulling it from the power outlet, then wiping with a dry cloth. Accumulated dust may cause an insulation defect from moisture, etc. resulting in a fire.
- Do not damage the power cord/plug. This may cause a short circuit, electric shock, and/or fire.
- Do not touch the plug with wet hands.

Battery caution

- We recommend using the battery(ies) noted on page 4. **Use only rechargeable battery(ies).**
- Do not mix old and new batteries.
- Do not dispose of the battery(ies) in a fire, as they may explode. Check with local waste management codes for special disposal instructions.
- Do not open or mutilate the battery(ies). Released electrolyte from the battery(ies) is corrosive and may cause burns or injury to the eyes

Preparation

or skin. The electrolyte may be toxic if swallowed.

- Exercise care when handling the battery(ies). Do not allow conductive materials such as rings, bracelets or keys to touch the battery(ies), otherwise a short circuit may cause the battery(ies) and/or the conductive material to overheat and cause burns.
- Charge the battery(ies) provided with or identified for use with this product only in accordance with the instructions and limitations specified in this manual.
- Only use a compatible base unit (or charger) to charge the battery(ies). Do not tamper with the base unit (or charger). Failure to follow these instructions may cause the battery(ies) to swell or explode.



廢電池請回收

Notice for product disposal, transfer, or return

This product can store your private/confidential information. To protect your privacy/confidentiality, we recommend that you erase the information such as phonebook or caller list entries from the memory before you dispose, transfer or return the product.

Information on Disposal in other Countries outside the European Union



This symbol is only valid in the European Union. If you wish to discard this product, please contact your local authorities or dealer and ask for the correct method of disposal.

Preparation

Controls

Base unit (KX-TG7200/KX-TG7202/
KX-TG7209)

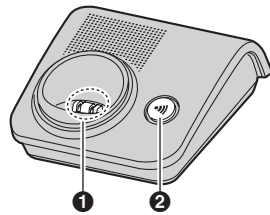

- 1 Charge contact
- 2 [Ⓜ] (Page)

Base unit (KX-TG7220)

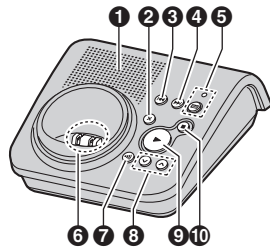

- 1 Speaker
- 2 [X] (Erase)
- 3 [⏮] (Repeat)
- 4 [⏭] (Skip)
- 5 [📞] (Answer on)/Answer on indicator
- 6 Charge contact
- 7 [Ⓜ] (Page)
- 8 [V][^] (Volume)
- 9 [▶] (Play)/Message indicator
- 10 [■] (Stop)

Handset

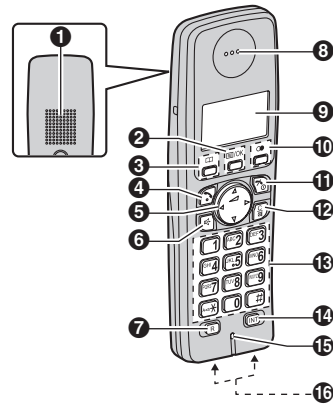

- 1 Speaker
- 2 [☰/OK] (Menu/OK)
- 3 [☰] (Phonebook)
- 4 [📞] (Talk)
- 5 Navigator key ([▲]/[▼]/[▶]/[←])/
▲ (Receiver volume: [▲][▼])
- 6 [📞] (Speakerphone)
- 7 [R] (Flash)
- 8 Receiver
- 9 Display
- 10 [⏻] (Redial/Pause)
- 11 [🔌] (Off/Power)
- 12 [C/📞] (Clear/Mute)
- 13 Dial keypad
- 14 [INT] (Intercom)
- 15 Microphone
- 16 Charge contacts

Preparation

Using the navigator key

Press [▲], [▼], [←], or [→] to navigate through menus and to select items shown on the display.

Adjusting the receiver or speaker volume (◀)

Press [▲] or [▼] while on a call.

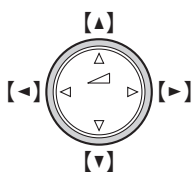

Displays

Display icons

Icon	Meaning
	Within range of a base unit <ul style="list-style-type: none"> When flashing: Handset is searching for base unit. (page 36)
	Handset is accessing base unit. (intercom, paging, changing base unit settings, etc.)
	Handset is on an outside call.
	Answering system is on.*1 (page 23)
	Battery level
[P]	Call privacy mode is on. (page 14)

Icon	Meaning
[IN USE]	<ul style="list-style-type: none"> Line is being used by another handset for calling, registration, etc. Answering system is being used by another handset or the base unit.*1

*1 KX-TG7220

Connections

Connect the telephone line cord until it clicks into the base unit and telephone line jack (1). Connect the AC adaptor cord (2) by pressing the plug firmly (3).

Base unit

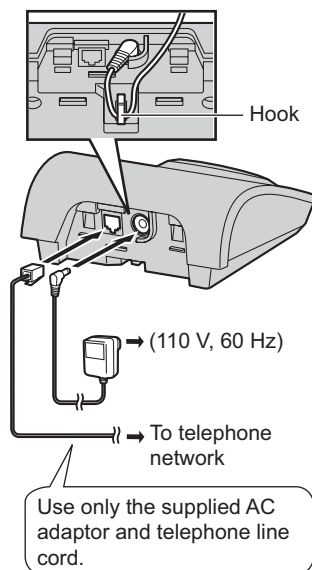

Preparation

Important:

- If you use a telephone line cord which is not supplied, the unit may not work properly.

Charger (KX-TG7202)

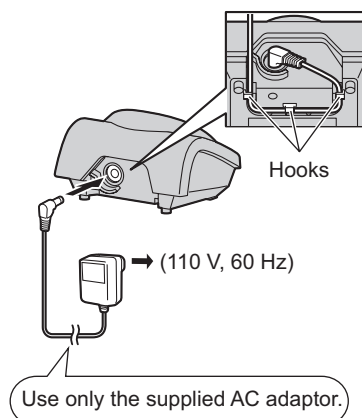

Note:

- Never install telephone wiring during a lightning storm.
- The AC adaptor must remain connected at all times. (It is normal for the adaptor to feel warm during use.)
- The AC adaptor should be connected to a vertically oriented or floor-mounted AC outlet. Do not connect the AC adaptor to a ceiling-mounted AC outlet, as the weight of the adaptor may cause it to become disconnected.

Location

- For maximum distance and noise-free operation, place your base unit:
 - away from electrical appliances such as TVs, radios, personal computers or other phones.
 - in a convenient, high and central location.

Battery installation and replacement

Important:

- Use only the supplied rechargeable batteries noted on page 4, 5.
- USE ONLY rechargeable Ni-MH batteries AAA (R03) size.
- Do NOT use Alkaline/Manganese/Ni-Cd batteries.
- Ensure correct polarities (+, -) when installing the batteries.
- Wipe the battery ends (+, -) with a dry cloth.
- When installing the batteries, avoid touching the battery ends (+, -) or the unit contacts.
- When replacing batteries, we recommend using the Panasonic rechargeable batteries noted on page 4, 5.

- 1 Press the notch on the handset cover firmly and slide it in the direction of the arrow.

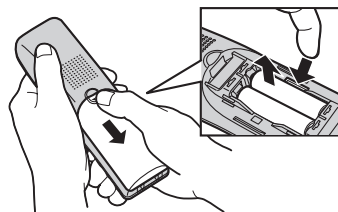

Preparation

2 Insert the batteries negative (⊖) end first. Close the handset cover.

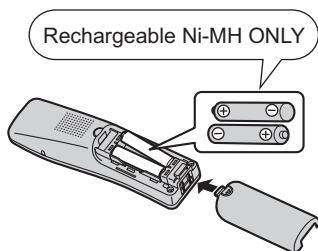

Note:

- When replacing batteries, remove the old batteries.

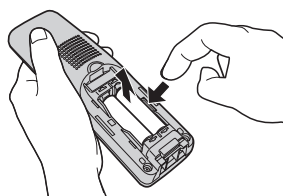

Battery charge

Place the handset on the base unit or charger for about 7 hours before initial use.

When charging, "Charging" will be displayed.

When the batteries are fully charged, "Charge Completed" will be displayed.

Base unit^{*1}

Charger^{*2}

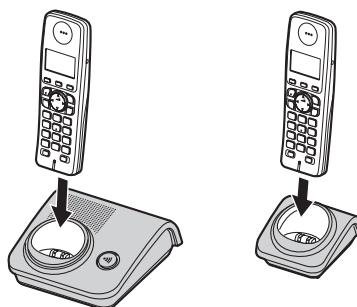

*1 The pictured model is KX-TG7200/KX-TG7209.

*2 KX-TG7202

Note:

- It is normal for the handset to feel warm during charging.
- If you want to use the unit immediately, charge the batteries for at least 15 minutes.
- Clean the charge contacts of the handset, base unit, and charger with a soft, dry cloth once a month. Clean more often if the unit is subject to the exposed of grease, dust, or high humidity.

Battery level

Battery icon	Battery level
	High
	Medium
	Low • When flashing: Needs to be charged.

Panasonic Ni-MH battery performance (supplied batteries)

Operation	Operating time
In continuous use	17 hours max.

Preparation

Operation	Operating time
In continuous standby mode	180 hours max.

Note:

- It is normal for batteries not to reach full capacity at the initial charge. Maximum battery performance is reached after a few complete cycles of charge/discharge (use).
- Actual battery performance depends on a combination of how often the handset is in use and how often it is not in use (standby).
- Even after the handset is fully charged, the handset can be left on the base unit or charger without any ill effect on the batteries.
- The battery level may not be displayed correctly after you replace the batteries. In this case, place the handset on the base unit or charger and let it charge for at least 7 hours.

Turning the power on/off

Power on

Press **[*]** for about 1 second.

Power off

Press **[*]** for about 2 seconds.

Setting up the unit before use

Display language

- 1 **[*]** → **[OK]**
- 2 Press **[▲]** or **[▼]** to select "Handset Setup". → **[▶]**
- 3 Press **[▲]** or **[▼]** to select "Display Setup". → **[▶]**
- 4 Press **[▲]** or **[▼]** to select "Select Language". → **[▶]**
- 5 Press **[▲]** or **[▼]** to select the desired language. → **[▶]** → **[*]**

Note:

- If you select a language you cannot read: **[*]** → **[OK]** → **[▲]** 3 times → **[▶]** → **[▼]** 2 times → **[▶]** 2 times → **[▲]**/**[▼]**: Select the desired language. → **[▶]** → **[*]**

Dialling mode (tone/pulse)

Changing the dialling mode depending on your telephone line service.



"**Tone**": Select when you have a touch-tone service.

"**Pulse**": Select when you have rotary/pulse service.

- 1 **[OK]**
- 2 Press **[▲]** or **[▼]** to select "Base Unit Setup". → **[▶]**
- 3 Press **[▲]** or **[▼]** to select "Call Options". → **[▶]**
- 4 Press **[▲]** or **[▼]** to select "Dial Mode". → **[▶]**
- 5 Press **[▲]** or **[▼]** to select the desired setting. → **[▶]** → **[*]**

Preparation

Date and time

- 1 **[/OK]**
- 2 Press [**▲**] or [**▼**] to select "Handset Setup". → [**▶**]
- 3 Proceed with the operation for your model.
 - **KX-TG7200/KX-TG7202/KX-TG7209**
Press [**▲**] or [**▼**] to select "Set Date & Time". → [**▶**]
 - **KX-TG7220**
Press [**▲**] or [**▼**] to select "Time Settings". → [**▶**] → Press [**▲**] or [**▼**] to select "Set Date & Time". → [**▶**]
- 4 Enter the current date, month, and year.
Example: 17 May, 2007
[1][7] [0][5] [0][7]
- 5 Enter the current hour and minute.
Example: 3:30 PM
[0][3] [3][0] → Press [*****] until "03:30 PM" is displayed.
- 6 **[/OK]** → [**⓪**]

Note:

- To correct a digit, press [**◀**] or [**▶**] to move the cursor, then make the correction.
- The date and time may be incorrect after a power failure. In this case, set the date and time again.

Making/Answering Calls

Making calls

- 1 Lift the handset and dial the phone number.
 - To correct a digit, press [C/⊗].
- 2 [↶]
- 3 When finished talking, press [⏏] or place the handset on the base unit or charger.

Speakerphone

- 1 During a conversation, press [📞] to turn on the speakerphone.
 - Speak alternately with the caller.
- 2 When finished talking, press [⏏].

Note:

- For best performance, use the speakerphone in a quiet environment.
- To switch back to the receiver, press [↶].

Adjusting the receiver or speaker volume

Press [▲] or [▼] while on a call.

Making a call using the redial list

The last 10 phone numbers dialed are stored in the redial list (each 24 digits max.).

- 1 [☉]
- 2 [▲]/[▼]: Select the desired number.
- 3 [↶]

Erasing numbers in the redial list

- 1 [☉]
- 2 [▲]/[▼]: Select the desired number. → [▶]
- 3 [▲]/[▼]: "Erase" → [▶]

- 4 [▲]/[▼]: "Yes" → [▶] → [⏏]

Pause (for PBX/long distance service users)

A pause is sometimes required when making calls using a PBX or long distance service.

Example: If you have to dial [0] before dialling outside numbers manually, you will probably need to pause after dialling [0] until you hear a dial tone.

- 1 [0] → [☉]
- 2 Dial the phone number. → [↶]

Note:

- A 3 second pause is inserted each time [☉] is pressed. Repeat as needed to create longer pauses.

Answering calls

- 1 Lift the handset and press [↶] or [📞] when the unit rings.
 - You can also answer the call by pressing any dial key from [0] to [9], [*], or [#]. (**Any key answer feature**)
- 2 When finished talking, press [⏏] or place the handset on the base unit or charger.

Auto talk feature

You can answer calls simply by lifting the handset off the base unit or charger. You do not need to press [↶]. To turn this feature on, see page 17.

Adjusting the handset ringer volume when receiving a call

Press [▲] or [▼].

Handset locator

Using this feature, you can locate the handset if it has been misplaced.

Making/Answering Calls

- 1 Press **[P]** on the base unit.
- 2 To stop paging, press **[P]** on the base unit or press **[*0]** on the handset.

Useful features during a call

Mute

While mute is turned on, you will be able to hear the other party, but the other party will not be able to hear you. To mute your voice, press **[C/ⓧ]**.

- To return to the conversation, press **[C/ⓧ]** again.

R button

Pressing **[R]** allows you to use special features of your host PBX such as transferring an extension call, or accessing optional telephone services.

Note:

- To change the flash time, see page 19.

Key lock

The handset can be locked so that no calls or settings can be made. Incoming calls can be answered, but all other functions are disabled while key lock is on.

To turn key lock on, press **[≡/OK]** for about 3 seconds.

- “**Key Lock**” is displayed.
- To turn key lock off, press **[≡/OK]** again for about 3 seconds.

Note:

- Calls to emergency numbers cannot be made until key lock is turned off.

Call share

A 2nd handset can join an existing outside call.

To join the conversation, press **[↶]** or **[↷]** when the other handset is on an outside call.

Call privacy

Call privacy allows you to prevent other users from joining your conversations with outside callers. To allow other users to join your conversations, leave this feature off. The default setting is “**OFF**”.

- 1 Press **[≡/OK]** during an outside call.
- 2 **[▲]/[▼]**: “**on**” or “**off**” → **[▶]**
 - When this feature is turned on, “**[P]**” is displayed.

Note:

- This feature will turn off after you hang up the call.

Temporary tone dialling (for rotary/pulse service users)

You can temporarily switch the dialling mode to tone when you need to access touch tone services (e.g., telephone banking services).

- 1 Make a call.
- 2 Press **[*]** when prompted to enter your code or PIN, then press the appropriate dial keys.

Note:

- The dialling mode will return to pulse when you hang up.

Phonebook**Handset phonebook**

The handset phonebook allows you to make calls without having to dial manually. You can add 50 names and phone numbers.

Adding entries

- 1 [] → []/OK
- 2 [▲]/[▼]: "New Entry" → [▶]
- 3 Enter the party's name (16 characters max.; page 33). → []/OK
- 4 Enter the party's phone number (24 digits max.). → []/OK
- 5 [▲]/[▼]: "Save" → [▶] → []

Note:

- Step 1 variation:
[]/OK → [▲]/[▼]: Select "Ph. Book Setup". → [▶]

Finding and calling a handset phonebook entry**Scrolling through all entries**

- 1 []
- 2 [▲]/[▼]: Select the desired entry.
- 3 [↶]

Searching by first character (index search) (KX-TG7220)

- 1 []
- 2 Press the dial key ([0] to [9]) which contains the character you are searching for (page 33).
 - Press the same dial key repeatedly to display the first entry corresponding to each letter located on that dial key.

- If there is no entry corresponding to the letter you selected, the next entry will be displayed.
- To change the character entry mode:
[] → [▲]/[▼]: Select the character entry mode. → [▶]

- 3 [▲]/[▼]: Scroll through the phonebook if necessary.
- 4 [↶]

Editing entries

- 1 Find the desired entry (page 15). → []/OK
- 2 [▲]/[▼]: "Edit" → [▶]
- 3 Edit the name if necessary (16 characters max.; page 33). → []/OK
- 4 Edit the phone number if necessary (24 digits max.). → []/OK
- 5 [▲]/[▼]: "Save" → [▶] → []

Erasing entries**Erasing an entry**

- 1 Find the desired entry (page 15). → []/OK
- 2 [▲]/[▼]: "Erase" → [▶]
- 3 [▲]/[▼]: "Yes" → [▶] → []

Erasing all entries

- 1 [] → []/OK
- 2 [▲]/[▼]: "Erase All" → [▶]
- 3 [▲]/[▼]: "Yes" → [▶]
- 4 [▲]/[▼]: "Yes" → [▶] → []

Chain dial

This feature allows you to dial phone numbers in the handset phonebook

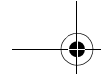

Phonebook



while you are on a call. This feature can be used, for example, to dial a calling card access number or bank account PIN that you have stored in the handset phonebook, without having to dial manually.

- 1** While on a call, press [□].
- 2** [▲]/[▼]: Select the desired entry.
- 3** Press [▶] to dial the number.

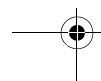
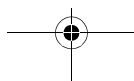
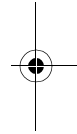
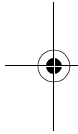

Handset Settings**Handset settings**

To customise the handset:

- 1 [☰/OK]
- 2 Press [▲] or [▼] to select "Handset Setup". → [▶]
- 3 Press [▲] or [▼] to select the desired item in the handset settings menu. → [▶]
- 4 Press [▲] or [▼] to select the desired item in the sub-menu. → [▶]
- 5 Press [▲] or [▼] to select the desired setting then press [▶].
 - This step may vary depending on the feature being programmed.
 - To exit the operation, press [✕⓪].

Note:

- The current item or setting is indicated by ▶ on the display.

Menu	Sub-menu	Details (default setting)
Set Date & Time ^{*1}	—	page 12
Time Settings ^{*2}	Set Date & Time	page 12
	Alarm	page 18
Ringer Setup	Ringer Volume	For handset (<i>Maximum</i>) ^{*3}
	Ext. Ringtone	For outside calls ("Ringtone 1") ^{*4*5}
Display Setup	Select Language	("English"): page 11
	Contrast	(<i>Level 3</i>)
Registration	Register H.set	page 29
Other Options	Keytones	("On")
	Auto Talk	("Off"): page 13

*1 KX-TG7200/KX-TG7202/KX-TG7203

*2 KX-TG7220

*3 When the ringer volume is turned off, "Ring Off" is displayed and the handset does not ring for outside calls.

However even when the ringer volume is turned off, the handset rings:

- at the minimum level for alarm (KX-TG7220)
- at the minimum level for intercom calls
- at the maximum level for paging

*4 If you select one of the melody ringtones, the ringtone will continue to sound for several seconds if the caller hangs up before you answer. You may hear a dial tone or no one on the line when you answer a call.

*5 The preset melodies in this product are used with permission of © 2006 Copyrights Vision Inc.

Handset Settings

Special instructions for time settings

Alarm (KX-TG7220)

An alarm will sound for 3 minutes at the set time once or daily. Set the date and time beforehand (page 12).

- 1 [M]/OK
- 2 [▲]/[▼]: "Handset Setup" → [▶]
- 3 [▲]/[▼]: "Time Settings" → [▶]
- 4 [▲]/[▼]: "Alarm" → [▶] 2 times
- 5 [▲]/[▼]: Select an alarm mode. → [▶]

Off	Turns alarm off. Press [▶] again, then press [ⓧ] to finish.
Once	The alarm sounds once at the set time. Enter the desired date and month.
Daily	An alarm sounds daily at the set time.

- 6 Enter the desired hour and minute. → [M]/OK
- 7 [▲]/[▼]: Select the desired ringtone. → [▶]
- 8 [▲]/[▼]: "Save" → [▶] → [ⓧ]

Note:

- To stop the alarm, press any dial key.
- When in talk or intercom mode, the alarm will not sound until the call has ended.
- If you select "Once", the setting will change to "Off" after the alarm sounds.

Base Unit Settings**Base unit settings**

To customise the base unit using the handset:

- 1 [M]/OK
- 2 Press [▲] or [▼] to select "Base Unit Setup". → [▶]
- 3 Press [▲] or [▼] to select the desired item in the base unit settings menu. → [▶]
- 4 Press [▲] or [▼] to select the desired item in the sub-menu. → [▶]
- 5 Press [▲] or [▼] to select the desired setting then press [▶].
 - This step may vary depending on the feature being programmed.
 - To exit the operation, press [END].

Note:

- The current item or setting is indicated by ▶ on the display.

Menu	Sub-menu	Details (default setting)
Ringer Volume ^{*1}	—	For base unit (Medium)
Call Options	Dial Mode	("Tone"): page 11
	Recall/Flash	Flash time ("600 msec.") ^{*2}
	Area Code	page 20
Other Options	Base Unit PIN	Change base unit PIN ("0000"). ^{*3} – Enter the current 4-digit base unit PIN. ^{*4} – Enter the new 4-digit base unit PIN. → [▶] → [END]

^{*1} KX-TG7220

^{*2} Change the flash time, if necessary, depending on the requirements of your service provider/telephone company or PBX.

^{*3} If you change the PIN, please make note of your new PIN. The unit will not reveal the PIN to you.

^{*4} If you forget your PIN, consult your nearest Panasonic service centre.

Base Unit Settings

Special instructions for call options

Selecting area codes to be deleted automatically

In some situations, phone numbers stored automatically in the Caller ID list (page 21) will include area codes. If you do not want to dial the area codes when making calls from the Caller ID list, you can store the area codes which you want the unit to delete automatically.

Example: You have stored the area code "123". If you make a call from the Caller ID list to the phone number "123-456-7890", the unit dials "456-7890".

- 1 [OK]
- 2 [▲]/[▼]: "Base Unit Setup" → [▶]
- 3 [▲]/[▼]: "Call Options" → [▶]
- 4 [▲]/[▼]: "Area Code" → [▶]
- 5 Enter an area code (5 digits max.). → [OK] → [⌂]

Caller ID Service**Using Caller ID service****Important:**

- This unit is Caller ID compatible. Please be sure that if both of you and the calling party's lines support Caller ID function without any problem at the same time or not.
- This unit is designed in accordance with DGT regulations and supports both DTMF and FSK Caller ID.
- If the unit's Caller ID features do not function properly, confirm that your phone line and the phone line of the caller supports Caller ID. Consult your local telephone company for more information.

Caller ID features

When an outside call is received, the caller's phone number will be displayed.

- Phone numbers of the last 50 callers will be logged in the caller list.
- While listening to a message recorded by the answering system using the handset, you can call back the caller without having to dial the phone number (KX-TG7220; page 25).
- When caller information is received and it matches a phone number stored in the unit's phonebook, the stored name will be displayed and logged in the caller list.
- If the unit is connected to a PBX system, you may not receive the caller information.
- When the caller dialed from an area which does not provide Caller ID service, "Out of Area" will be displayed.*1
- When the caller requested not to send caller information, either no

information or "Private Caller" will be displayed.*1

- *1 When the Caller ID data is sent by FSK mode from your telephone company's PBX.

Missed calls

If a call is not answered, the unit treats the call as a missed call. The number of missed calls is shown on the display. This lets you know if you should view the caller list to see who called while you were out.

Caller list**Viewing the caller list and calling back**

- 1 **[☰/OK]**
- 2 **[▲]/[▼]: "Caller List" → [▶]**
- 3 Press **[▼]** to search from the most recent call, or press **[▲]** to search from the oldest call.
 - If the item has already been viewed or answered, "✓" is displayed, even if it was viewed or answered using another handset.
- 4 **[↶]**

Note:

- If you do not want to dial the area codes when making calls from the Caller ID list, you can store the area codes which you want the unit to delete automatically (page 20).

Editing a caller's phone number before calling back

- 1 **[☰/OK]**
- 2 **[▲]/[▼]: "Caller List" → [▶]**

Caller ID Service

- 3 **[▲]/[▼]**: Select the desired entry.
→ **[≡/OK]**
- 4 **[▲]/[▼]**: "Edit and Call" → **[▶]**
- 5 Edit the number.
 - Press dial key (**[0]** to **[9]**) to add, **[C/✕]** to delete.
- 6 **[↶]**

Erasing caller information

- 1 **[≡/OK]**
- 2 **[▲]/[▼]**: "Caller List" → **[▶]**
- 3 **[▲]/[▼]**: Select the desired entry.
→ **[≡/OK]**
- 4 **[▲]/[▼]**: "Erase" or "Erase All" → **[▶]**
- 5 **[▲]/[▼]**: "Yes" → **[▶]** → **[✕⊙]**

Storing caller information into the handset phonebook

- 1 **[≡/OK]**
- 2 **[▲]/[▼]**: "Caller List" → **[▶]**
- 3 **[▲]/[▼]**: Select the desired entry.
→ **[≡/OK]**
- 4 **[▲]/[▼]**: "Add Phonebook" → **[▶]**
- 5 Continue from step 3, "Adding entries", page 15.

Voice mail service

Voice mail is an automatic answering service offered by your service provider/telephone company. If you subscribe to this service, your service provider/telephone company's voice mail system will answer calls for you when you are unavailable to answer the phone or when your line is busy.

Messages are recorded by your service provider/telephone company, not your telephone. Please consult your service provider/telephone company for details of this service.

Note:

- To use the voice mail service provided by your service provider/telephone company rather than the unit's answering system, turn off the answering system (page 23). For details, see page 27 (KX-TG7220).

Answering System Features

Answering system

Available for:
KX-TG7220

The answering system can answer and record calls for you when you are unavailable to answer the phone.

Important:

- Only 1 person can access the answering system (listen to messages, record a greeting message, etc.) at a time.
- When callers leave messages, the unit records the date and time of each message. Make sure the date and time have been set (page 12).

Memory capacity

The total recording capacity (including your greeting message and caller messages) is about 20 minutes. A maximum of 64 messages can be recorded.

Note:

- If message memory becomes full:
 - “Answer Sys. Full” is shown on the handset display
 - [▶] on the base unit flashes rapidly

Turning the answering system on/off

Using the base unit

Press [☐] to turn on/off the answering system.

- When the answering system is turned on, the answer on indicator lights up.

Using the handset

- 1 [☐/OK]
- 2 [▲]/[▼]: “Answer System” → [▶]
- 3 [▲]/[▼]: “Answer On” or “Answer Off” → [▶] → [📞]

Note:

- When the answering system is turned on, [☐] is displayed.

Greeting message

When the unit answers a call, callers are greeted by a greeting message.

Recording a greeting message

You can record your own greeting message (2 minutes and 30 seconds max.).

- 1 [☐/OK]
- 2 [▲]/[▼]: “Answer System” → [▶]
- 3 [▲]/[▼]: “Record Greeting” → [▶]
 - Hold the handset about 20 cm away and speak clearly into the microphone.
- 4 Press [☐/OK] to stop recording.
- 5 [📞]

Using a pre-recorded greeting message

If you erase or do not record your own greeting message, the unit plays a pre-recorded greeting message for callers and asks them to leave messages. If the message recording time (page 27) is set to “Greeting Only”, caller messages

Answering System Features

will not be recorded and the unit will play a different pre-recorded greeting message asking callers to call again.

Playing back the greeting message

- 1 [M]/OK
- 2 [▲]/[▼]: "Answer System" → [▶]
- 3 [▲]/[▼]: "Play Greeting" → [▶]
- 4 [✕]0

Erasing the greeting message

If you erase your own greeting message, the unit will play a pre-recorded greeting message for callers.

- 1 [M]/OK
- 2 [▲]/[▼]: "Answer System" → [▶]
- 3 [▲]/[▼]: "Erase Message" → [▶]
- 4 [▲]/[▼]: "Erase Greeting" → [▶]
- 5 [▲]/[▼]: "Yes" → [▶] → [✕]0

Listening to messages

Listening to new/all messages

When you have new messages, [▶] on the base unit flashes.

Note:

When [▶] on the base unit flashes rapidly, the message memory is full ("Memory capacity", page 23).

Using the base unit

Press [▶].

- If new messages have been recorded, the base unit plays back new messages.
- If there are no new messages, the base unit plays back all messages.

Using the handset

- 1 [M]/OK
- 2 [▲]/[▼]: "Answer System" → [▶]
- 3 [▲]/[▼]: "Play New Msg." or "Play All Msg." → [▶]

Operations during playback

■ To adjust the speaker volume:

- for the base unit, press [Λ] or [V]
- for the handset, press [▲] or [▼]

■ To repeat a message:

- for the base unit, press [◀◀]
- for the handset, press [◀]

If pressed within the first 5 seconds of a message, the previous message will be played.

■ To skip a message:

- for the base unit, press [▶▶]
- for the handset, press [▶]

■ To stop a message:

- for the base unit, press [■]
- for the handset, press [9]

■ To erase a message:

- for the base unit, press [X]
- for the handset, press [*][4]

Erasing all messages

Using the base unit

Press [X] 2 times.

Using the handset

- 1 [M]/OK

Answering System Features

- 2 [▲]/[▼]: "Answer System" → [▶]
- 3 [▲]/[▼]: "Erase Message" → [▶]
- 4 [▲]/[▼]: "Erase All" → [▶]
- 5 [▲]/[▼]: "Yes" → [▶] → [✕] [0]

Calling back (Caller ID subscribers only)

If caller information was received for the call, you can call the caller back while listening to a message.

- 1 Press [≡/OK] during playback.
- 2 [▲]/[▼]: "Call Back" → [▶]

Editing the number before calling back

- 1 Press [≡/OK] during playback.
- 2 [▲]/[▼]: "Edit and Call" → [▶]
- 3 Edit the number. → [↶]

Direct command operation using the handset

You can operate the answering system by pressing dial keys, rather than navigating through the menus.

To use the following commands:

[≡/OK] → [▲]/[▼]: "Answer System" → [▶]

Key	Operation
[1]	Repeat message (during playback) ^{*1}
[2]	Skip message (during playback)

Key	Operation
[3]	Enter the "Settings" menu
[4]	Play new messages
[5]	Play all messages
[6]	Play greeting message
[7][6]	Record greeting message
[8]	Turn answering system on
[9]	Stop (recording, playback)
[0]	Turn answering system off
[*][4]	Erase currently playing message
[*][5]	Erase all messages
[*][6]	Erase greeting message

*1 If pressed within the first 5 seconds of a message, the previous message will be played.

Remote operation

Using a touch-tone phone, you can call your phone number from outside and access the unit to listen to messages or change answering system settings. The unit's voice guidance will prompt you to press certain dial keys to perform different operations.

Important:

- In order to operate the answering system remotely, you must first turn on remote operation by setting a remote access code. This code must be entered each time you operate the answering system remotely.

Answering System Features

Turning remote operation on

A 3-digit remote access code must be entered when operating the answering system remotely. This code prevents unauthorised parties from listening to your messages remotely.

- 1 **[M]/[OK]**
- 2 **[▲]/[▼]**: "Answer System" → **[▶]**
- 3 **[▲]/[▼]**: "Settings" → **[▶]**
- 4 **[▲]/[▼]**: "Remote Code" → **[▶]**
- 5 To turn on remote operation, enter a 3-digit remote access code.
 - To turn off remote operation, press **[*]**.
- 6 **[M]/[OK]** → **[*][0]**

Using the answering system remotely

- 1 Dial your phone number from a touch-tone phone.
- 2 After the greeting message starts, enter your remote access code.
 - The unit will announce the number of new messages.
 - After 3 seconds, voice guidance starts.
- 3 Follow the voice guidance prompts as necessary.

Note:

- You can hang up at any time.

Voice guidance

During remote operation, the unit's voice guidance will prompt you to press **[1]** to perform a specific operation, or press **[2]** to listen to more available operations.

Remote commands

You can press dial keys to access certain answering system functions without waiting for the voice guidance to prompt you.

Key	Operation
[1]	Repeat message (during playback) ^{*1}
[2]	Skip message (during playback)
[4]	Play new messages
[5]	Play all messages
[6]	Play greeting message
[7]	Record greeting message
[9]	Stop (recording, playback)
[0]	Turn answering system off
[*][4]	Erase currently playing message
[*][5]	Erase all messages
[*][6]	Erase greeting message (during greeting message playback)
[*][#]	End remote operation (or hang up)

*1 If pressed within the first 5 seconds of a message, the previous message will be played.

Turning on the answering system remotely

If the answering system is off, you can turn it on remotely.

- 1 Dial your phone number from a touch-tone phone.
- 2 Let the phone ring 20 times.
 - A long beep will be heard.

Answering System Features

- 3 Enter your remote access code within 10 seconds after the long beep.
 - The greeting message is played back.
 - You can hang up, or enter your remote access code again and begin remote operation.

- 3 [▲]/[▼]: "Settings" → [▶]
- 4 [▲]/[▼]: "Number of Rings" → [▶]
- 5 [▲]/[▼]: Select the desired setting. → [▶] → [↶⊙]

Answering system settings

Setting (default setting)	Page
Answering system on/off (Answer On)	23
Remote access code (—)	26
Number of rings (3 Rings)	27
Caller's recording time (3 Minutes)	27
Call screening (On)	28

Number of rings

You can change the number of times the phone rings before the unit answers calls. You can select 2 to 7 rings, or "Auto".

"Auto": The unit answers after 2 rings when new messages have been recorded, and after 5 rings when there are no new messages. If you call your phone from outside to listen to new messages (page 26), you will know that there are no new messages when the phone rings for the 3rd time. You can then hang up without being charged for the call.

- 1 [≡/OK]
- 2 [▲]/[▼]: "Answer System" → [▶]

For voice mail service subscribers

Please note the following:

- To receive messages correctly with your voice mail service, we recommend that you do not use the unit's answering system. Make sure that the answering system is turned off (page 23).
- If you would rather use the unit's answering system than the voice mail service provided by your service provider/telephone company, ask your service provider/telephone company to deactivate your voice mail service. If your service provider/telephone company cannot do this, set this unit's "Number of Rings" setting so that this unit's answering system answers calls before your service provider/telephone company's voice mail service tries to answer your calls. It is necessary to check the number of rings required to activate the voice mail service provided by your service provider/telephone company before changing this setting.

Caller's recording time

You can change the maximum message recording time allotted to each caller, or set the unit to greet callers but not record messages.

- 1 [≡/OK]
- 2 [▲]/[▼]: "Answer System" → [▶]
- 3 [▲]/[▼]: "Settings" → [▶]
- 4 [▲]/[▼]: "Recording Time" → [▶]

Answering System Features

- 5 [▲]/[▼]: Select the desired setting.
→ [▶] → [✕⊙]

Call screening

While a caller is leaving a message, you can screen the call through the handset speaker.

- 1 [≡]/OK
- 2 [▲]/[▼]: "Answer System" → [▶]
- 3 [▲]/[▼]: "Settings" → [▶]
- 4 [▲]/[▼]: "Call Screening" → [▶]
- 5 [▲]/[▼]: "On" or "Off" → [▶] → [✕⊙]

Multi-unit Operation

Operating additional units

Additional handsets

Up to 6 handsets can be registered to the base unit.

Important:

- The additional handset model recommended for use with this unit is noted on page 4. If other model handset is used, certain operations (handset settings, base unit settings, etc.) may not be available.
- Additional handsets will give you the freedom to, for example, have an intercom call with another handset while a third handset is on an outside call.

Registering a handset to the base unit

The supplied handset and base unit are pre-registered. When you purchase an additional handset, refer to the additional handset's installation manual for registration. If for some reason the handset is not registered to the base unit (for example, ∇ flashes even when the handset is near the base unit), register the handset.

- 1 **[\square]/OK**
- 2 **[\blacktriangle]/ ∇** : "Handset Setup" \rightarrow **[\blacktriangleright]**
- 3 **[\blacktriangle]/ ∇** : "Registration" \rightarrow **[\blacktriangleright]**
- 4 **[\blacktriangle]/ ∇** : "Register H.set" \rightarrow **[\blacktriangleright]**
- 5 Proceed with the operation for your model.

■ KX-TG7200/KX-TG7202/ KX-TG7209

Press and hold **[\blacktriangle]** on the base unit for about 5 seconds. (No registration tone)

■ KX-TG7220

Press and hold **[\blacktriangle]** on the base unit for about 5 seconds, until the registration tone sounds.

- If all registered handsets start ringing, press **[\blacktriangle]** to stop, then repeat this step.
 - After pressing **[\blacktriangle]**, the rest of this procedure must be completed within 90 seconds.
- 6 Wait until "Enter Base PIN" is displayed. \rightarrow Enter the base unit PIN (default: "0000"). \rightarrow Press **[\square]/OK**.
 - If you forget your PIN, consult your nearest Panasonic service centre.
 - When the handset has been registered successfully, ∇ will stop flashing. If the key tone is turned on (page 17), a confirmation tone will be heard.

Deregistering a handset

A handset can cancel its own registration (or the registration of another handset) that is stored in the base unit. This will allow the base unit to "forget" the handset.

- 1 **[\square]/OK**
- 2 **[\blacktriangle]/ ∇** : "Base Unit Setup" \rightarrow **[\blacktriangleright]**
- 3 Enter "335".
- 4 **[\blacktriangle]/ ∇** : "Deregistration" \rightarrow **[\blacktriangleright]**
 - The numbers of all handsets registered to the base unit are displayed.

Multi-unit Operation

- 5 Select the handset(s) you want to cancel, by pressing the desired handset number. → [OK]
 - The selected handset number(s) will flash.
 - To cancel a selected handset number, press the number again. The number will stop flashing.
- 6 [▲]/[▼]: “Yes” → [▶]
 - A long beep will sound as each handset number disappears.
 - The handset does not beep when cancelling its own registration.
- 7 [✕⓪]

- During an outside call, press [INT].
→ Press [2] (desired handset number).
- The outside call will be put on hold.
 - If there is no answer, press [INT] to return to the outside call.
- 2 **Handset 2:**
Press [↶] to answer the page.
 - Handset 2 can talk with handset 1.
 - 3 **Handset 1:**
To complete the call transfer, press [✕⓪].

Intercom between handsets

Intercom calls can be made between handsets.

Example: When handset 1 calls handset 2

- 1 **Handset 1:**
[INT] → Press [2] (desired handset number).
- 2 **Handset 2:**
[↶]
- 3 When finished talking, press [✕⓪].

Transferring a call without speaking to the other handset user

- 1 During an outside call, press [INT].
→ Press the desired handset number.
 - [↶] flashes to indicate the outside call is on hold.
- 2 [✕⓪]
 - The outside call rings at the other handset.

Note:

- If the other handset user does not answer the call within 1 minute, the call will ring at your handset again.

Transferring calls between handsets

Outside calls can be transferred between 2 people.

Example: When handset 1 transfers a call to handset 2

- 1 **Handset 1:**

Conference calls

2 people can have a conference call with an outside party. The following 2 methods are available:

- Another person presses [↶] or [☎] while one person is talking with an outside party (“Call share”, page 14).
- One person pages another person during an outside call as follows (KX-TG7220).

Multi-unit Operation

Example: When handset 1 pages a call to handset 2

1 Handset 1:

During an outside call, press **[INT]**.
→ Press **[2]** (desired handset number).

- The outside call will be put on hold.
- If there is no answer, press **[INT]** to return to the outside call.

2 Handset 2:

Press **[📞]** to answer the page.

- Handset 2 can talk with handset 1.

3 Handset 1:

To establish a conference call, press **[3]**.

[▲]/[▼]: "yes" → [▶] → Find the desired handset phonebook entry. → [▶]

4 [📞Ⓞ]

Copying phonebook entries

Available for:
KX-TG7220

You can copy handset phonebook entries to the handset phonebook of another compatible Panasonic handset.

Copying one entry

1 Find the desired handset phonebook entry (page 15). → **[📄/OK]**

2 **[▲]/[▼]: "Copy" → [▶]**

3 Enter the handset number you wish to send the handset phonebook entry to.

- When an entry has been copied, "Completed" is displayed.
- To continue copying another entry:

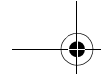

Multi-unit Operation



Copying all entries

- 1** [□] → [≡/OK]
- 2** [▲]/[▼]: "Copy All" → [▶]
- 3** Enter the handset number you wish to send the handset phonebook entry to.
 - When all entries have been copied, "Completed" is displayed.
- 4** [✕⊙]

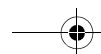
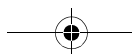
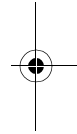
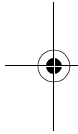

Useful Information

Character entry

The dial keys are used to enter characters and numbers. Each dial key has multiple characters assigned to it. The available character entry modes are Alphabet (ABC), Numeric (0-9), Greek (ABΓ), Extended 1 (AÄÅ), Extended 2 (ŠŠŠ), and Cyrillic (АБВ). When in these entry modes except Numeric, you can select which character is entered by pressing a dial key repeatedly.

- Press [◀] or [▶] to move the cursor.
- Press dial keys to enter characters and numbers.
- Press [C/⌫] to erase the character or number highlighted by the cursor. Press and hold [C/⌫] to erase all characters or numbers.
- Press [✱] to switch between uppercase and lowercase.
- To enter another character located on the same dial key, press [▶] to move the cursor to the next space, then press the appropriate dial key.

Character entry modes

Several character entry modes can be used when entering text. The characters that can be entered depend on the entry mode.

Characters available in each character entry mode

When the unit displays the character entry screen:

[□] → [▲]/[▼]: Select a character entry mode. → [▶]

Alphabet character table (ABC)

0	1	ABC 2	DEF 3	GHI 4	JKL 5	MNO 6	PQRS 7	TUV 8	WXYZ 9
Space	Space #	A B C	D E F	G H I	J K L	M N O	P Q R S	T U V	W X Y Z
0	& ' () * , - . / 1	2	3	4	5	6	7	8	9
		a b c	d e f	g h i	j k l	m n o	p q r s	t u v	w x y z
		2	3	4	5	6	7	8	9

Numeric entry table (0-9)

0	1	ABC 2	DEF 3	GHI 4	JKL 5	MNO 6	PQRS 7	TUV 8	WXYZ 9
0	1	2	3	4	5	6	7	8	9

Greek character table (ABΓ)

0	1	ABC 2	DEF 3	GHI 4	JKL 5	MNO 6	PQRS 7	TUV 8	WXYZ 9
Space	Space #	A B Γ	Δ E Z	H Θ I	K Λ M	N Ξ O	Π P Σ	T Υ Φ	X Ψ Ω Ὢ
0	& ' () * , - . / 1	2	3	4	5	6	7	8	9

Useful Information

Extended 1 character table (AÄÅ)

0	1	ABC2	DEF3	GHI4	JKL5	MNO6	PQRS7	TUV8	WXYZ9
Space # 0	Space # & ' () * , - . / 1	A Ä Å Á Â Ã Ä Æ B C Ç 2	D E È É Ê Ë Ë F 3	G Ğ H I Ì Í Î Ï 4	J K L 5	M N Ñ O Ö Ó Ô Õ Ö ø 6	P Q R S Ş ß 7	T U Ü Ú Û Ü Û V 8	W X Y Ŵ Ŷ Ÿ Z 9
		a à á â ã ä å æ b c ç 2	d e è é ê ë ë f 3	g ğ h i ì í î ï 4	j k l 5	m n ñ o ö ó ô õ ö ø 6	p q r s ş ß 7	t u ü ú û ü ü v 8	w x y ŵ ŷ Ź Z 9

- The following are used for both uppercase and lowercase: ø Ş Ŵ Ŷ Ź

Extended 2 character table (ŠŠš)

0	1	ABC2	DEF3	GHI4	JKL5	MNO6	PQRS7	TUV8	WXYZ9
Space # 0	Space # & ' () * , - . / 1	A Ä Å A B C C Ć 2	D Ć E É Ę Ě F 3	G H I Í 4	J K L Ł Ł Ł 5	M N Ń Ń O Ó Ō Ő 6	P Q R Š Ŕ Š Ś Š 7	T Ť U Ú Ů ů ú v 8	W X Y y Ÿ Z Z Ž Z 9
		a á ä A b c C Ć 2	d ě e é Ę ě f 3	g h i Í 4	j k l Ł Ł Ł 5	m n Ń ń o ó ō ő 6	p q r Š ŕ š ś š 7	t ť u ú ű ů ű v 8	w x y y ÿ z ž ž Z 9

- The following are used for both uppercase and lowercase:

A Ć Ć Ę Ł Ł Ł Ń Ŕ Š Ś ů ŷ Ž Ž Ž

Cyrillic character table (АБВ)

0	1	ABC2	DEF3	GHI4	JKL5	MNO6	PQRS7	TUV8	WXYZ9
Space # 0	Space # & ' () * , - . / 1	А Б В Г 2	Д Е Ж З 3	И Й К Л 4	М Н О П 5	Р С Т У 6	Ф Х Ц Ч 7	Ш Щ Ъ Ъ 8	Ь Э Ю Я 9

Useful Information**Error messages**

Error message	Cause & solution
Answer Sys. Full ^{*1}	<ul style="list-style-type: none"> • Erase unnecessary messages (page 24).
Error ^{*1}	<ul style="list-style-type: none"> • Recording was too short. Try again.
Failed ^{*1}	<ul style="list-style-type: none"> • Phonebook copy failed. Confirm the other handset (the receiver) is in standby mode and try again.
Incomplete ^{*1}	<ul style="list-style-type: none"> • The receiver's phonebook memory is full. Erase the unnecessary phonebook entries from the other handset (the receiver) and try again.
Memory Full	<ul style="list-style-type: none"> • The handset's phonebook memory is full. Erase unnecessary entries (page 15). • Message memory becomes full. Erase unnecessary messages (page 24).^{*1}
No link to base. Move closer to base, try again.	<ul style="list-style-type: none"> • The handset has lost communication with the base unit. Move closer to the base unit and try again. • Unplug the base unit's AC adaptor to reset the unit. Reconnect the adaptor and try again. • The handset's registration may have been cancelled. Re-register the handset (page 29).
You must first subscribe to Caller ID.	<ul style="list-style-type: none"> • You must subscribe to Caller ID service. Once you receive caller information after subscribing to Caller ID service, this message will not be displayed.

*1 KX-TG7220

Troubleshooting



If you still have difficulties after following the instructions in this section, disconnect the base unit AC adaptor and turn off the handset, then reconnect the base unit AC adaptor and turn on the handset.

Useful Information

Telephone

Problem	Cause & solution
Y is flashing.	<ul style="list-style-type: none"> ● The handset is not registered to the base unit. Register it (page 29). ● The handset is too far from the base unit. Move closer. ● The base unit AC adaptor is not connected. Check the connections. ● You are using the handset or base unit in an area with high electrical interference. Place the handset and base unit away from interference sources, such as antennas and mobile phones.
The handset display is blank.	<ul style="list-style-type: none"> ● The handset is not turned on. Turn the power on (page 11).
The handset will not turn on.	<ul style="list-style-type: none"> ● Make sure that the batteries are installed correctly (page 9). ● Fully charge the batteries (page 10). ● Clean the charge contacts and charge again (page 10).
I have changed the display language to a language I cannot read.	<ul style="list-style-type: none"> ● Change the display language (page 11).
I cannot make or receive calls.	<ul style="list-style-type: none"> ● The base unit AC adaptor or telephone line cord is not connected. Check the connections. ● If you are using a splitter to connect the unit, remove the splitter and connect the unit to the wall socket directly. If the unit operates properly, check the splitter. ● Disconnect the base unit from the telephone line and connect the line to a known working telephone. If the working telephone operates properly, contact our service personnel to have the unit repaired. If the working telephone does not operate properly, contact your service provider/telephone company. ● The dialling mode setting is incorrect. Set to "Tone" or "Pulse" as needed (page 11). ● The key lock feature is turned on. Turn it off (page 14).
The unit does not ring.	<ul style="list-style-type: none"> ● The ringer volume is turned off. Adjust the ringer volume (page 17, 17, 19).

Useful Information

Problem	Cause & solution
The batteries should be charging but the battery icon does not change.	<ul style="list-style-type: none"> ● Clean the charge contacts and charge again (page 10).
A busy tone is heard when [] is pressed.	<ul style="list-style-type: none"> ● The handset is too far from the base unit. Move closer and try again. ● Another handset is in use or the answering system is being used. Wait and try again later.
Static is heard, sound cuts in and out. Interference from other electrical units.	<ul style="list-style-type: none"> ● Place the handset and the base unit away from other electrical appliances. ● Move closer to the base unit. ● Your unit is connected to a telephone line with ADSL service (page 39).
Noise is heard during a call.	<ul style="list-style-type: none"> ● You are using the handset or base unit in an area with high electrical interference. Place the handset and base unit away from interference sources, such as antennas and mobile phones.
The handset/base unit stops working while being used.	<ul style="list-style-type: none"> ● Disconnect the base unit AC adaptor and turn off the handset. Connect the base unit AC adaptor, turn on the handset and try again.
The handset beeps intermittently and/or  flashes.	<ul style="list-style-type: none"> ● Fully charge the batteries (page 10).
I fully charged the batteries, but  still flashes.	<ul style="list-style-type: none"> ● Clean the charge contacts and charge again (page 10). ● It is time to replace the batteries (page 9).
I fully charged the batteries, but the operating time seems to be short.	<ul style="list-style-type: none"> ● Wipe the battery ends (+, -) and the unit contacts with a dry cloth.
Caller information is not displayed.	<ul style="list-style-type: none"> ● Please be sure that if both of you and the calling party's lines support Caller ID function without any problem at the same time or not. ● Your unit is connected to a telephone line with ADSL service (page 39).
I cannot register a handset to the base unit.	<ul style="list-style-type: none"> ● The maximum number of handsets (6) are already registered to the base unit. Cancel unused handset registrations from the base unit (page 29). ● You entered the wrong PIN. If you forget your PIN, consult your nearest Panasonic service centre. ● Place the handset and the base unit away from other electrical appliances.

Useful Information

Problem	Cause & solution
I do not know how to erase the missed call number.	<ul style="list-style-type: none"> • There are unviewed missed calls remaining. View them using the following method. 1 [☒]/OK 2 [▲]/[▼]: Caller List → [▶] 3 Press [▼] to search from the most recent call, or press [▲] to search from the oldest call.

Answering system (KX-TG7220)

Problem	Cause & solution
The unit does not record new messages.	<ul style="list-style-type: none"> • The answering system is turned off. Turn it on (page 23). • The recording time is set to "Greeting Only". Select "1 Minute" or "3 Minutes" (page 27). • If you subscribe to the voice mail service, messages are recorded by your service provider/telephone company not your telephone. Change the unit's "Number of Rings" setting or consult your service provider/telephone company (page 27).
I cannot operate the answering system with the handset.	<ul style="list-style-type: none"> • The base unit or another handset is being used. Wait for the other user to finish. • A caller is leaving a message. Wait for the caller to finish. • The handset is too far from the base unit. Move closer.
When I try to operate the answering system with the base unit, the answer on indicator on the base unit flashes for a few seconds and I cannot operate the answering system.	<ul style="list-style-type: none"> • Another handset is being used. Wait for the other user to finish. • A caller is leaving a message. Wait for the caller to finish.
I cannot operate the answering system remotely.	<ul style="list-style-type: none"> • You are entering the wrong remote access code. If you forget the remote access code, store a new remote access code (page 26). • Press each key firmly. • The answering system is turned off. Turn it on (page 26). • You are using a rotary/pulse telephone. Try again using a touch-tone phone.



Useful Information

Problem	Cause & solution
While recording a greeting message or listening to messages, the unit rings and recording stops.	<ul style="list-style-type: none">• A call is being received. Answer the call and try again later.

For ADSL users

We recommend connecting a filter (contact your ADSL service provider) to the telephone line between the base unit and the telephone line jack.

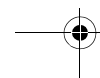
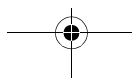
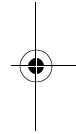
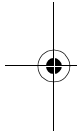

Useful Information

Specifications

- **Standard:**
DECT (Digital Enhanced Cordless Telecommunications),
GAP (Generic Access Profile)
- **Number of channels:**
96 Duplex Channels
- **Frequency range:**
1.88 GHz to 1.9 GHz
- **Duplex procedure:**
TDMA (Time Division Multiple Access)
- **Channel spacing:**
1,728 kHz
- **Bit rate:**
1,152 kbit/s
- **Modulation:**
GFSK (Gaussian Frequency Shift Keying)
- **RF transmission power:**
Approx. 250 mW
- **Voice coding:**
ADPCM 32 kbit/s
- **Power source:**
110 V, 60 Hz
- **Power consumption**
Base unit^{*1}:
Standby: Approx. 1.7 W
Maximum: Approx. 4.8 W
Base unit^{*2}:
Standby: Approx. 1.8 W
Maximum: Approx. 5.2 W
Charger^{*3}:
Standby: Approx. 0.9 W
Maximum: Approx. 4.2 W
- **Operating conditions:**
5 °C–40 °C, 20 %–80 % relative air humidity (dry)
- **Dimensions:**
Base unit: Approx. 54 mm × 122 mm × 137 mm

Handset: Approx. 155 mm × 48 mm × 32 mm
Charger^{*3}: Approx. 53 mm × 81 mm × 91 mm

- **Mass (weight):**
Base unit^{*1}: Approx. 190 g
Base unit^{*2}: Approx. 210 g
Handset: Approx. 130 g
Charger^{*3}: Approx. 60 g

*1 KX-TG7200/KX-TG7202/KX-TG7209
*2 KX-TG7220
*3 KX-TG7202

Note:

- Specifications are subject to change.
- The illustrations used in these operating instructions may differ slightly from the actual product.

Index

- A** Additional handsets: 29
- Alarm: 18
- Answering calls: 13
- Answering system: 23
 - Listening to messages: 24
 - Remote operation: 25
 - Settings: 27
 - Turning on/off: 23
- Auto talk: 13, 17
- B** Base unit
 - Settings: 19
- Battery: 9, 10
- C** Caller ID service: 21
- Call privacy: 14
- Call share: 14
- Chain dial: 15
- Character entry: 33
- Conference calls: 30
- D** Date and time: 12
- Dialling mode: 11
- Display
 - Contrast: 17
 - Icons: 8
 - Language: 11
- F** Flash: 14, 19
- H** Handset
 - Deregistration: 29
 - Locator: 13
 - Registration: 29
 - Settings: 17
- I** Intercom: 30
- K** Key lock: 14
- Keytones: 17
- M** Making calls: 13
- Missed calls: 21
- Mute: 14
- P** Pause: 13
- Phonebook
 - Handset phonebook: 15
- Phonebook copy: 31
- PIN: 19
- Power on/off: 11
- R** Recording
 - Greeting message: 23
- Redialling: 13
- Registration: 29
- Ringtone: 17
- S** Speakerphone: 13
- T** Temporary tone dialling: 14
- Transfer calls: 30
- V** Voice mail: 22
- Volume
 - Receiver: 13
 - Ringer (Handset): 17
 - Speakerphone: 13



Notes

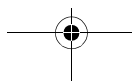
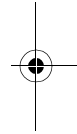
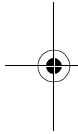



Notes

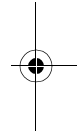

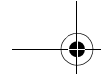

Sales Department:

松下資訊科技股份有限公司

Panasonic Systems Sales Taiwan Co.,Ltd.
台北縣中和市員山路579號
TEL: (02)2227-6100
台中營業所 (04)2472-0088
台南事務所 (06)223-3562
高雄營業所 (07)237-0399
網址: <http://psst.panasonic.com.tw>

Copyright:

This manual is copyrighted by
Panasonic Systems Sales Taiwan Co.,Ltd. (PSST).
Under the copyright laws, this manual
may not be reproduced in any form, in
whole or part, without the prior written
consent of PSST.

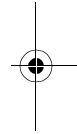
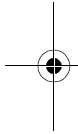

製造商：

松下通信系統設備株式會社

Panasonic Communications Co., Ltd.

Copyright:

This material is copyrighted by Panasonic Communications Co., Ltd., and may be
reproduced for internal use only. All other reproduction, in whole or in part, is
prohibited without the written consent of Panasonic Communications Co., Ltd.

© 2007 Panasonic Communications Co., Ltd. All Rights Reserved.



TG7200TW

PQQX16080ZA CC0807DS0

